

TECHNICAL DIAGNOSTICS AND MODERNIZATION OF THE DRILLING SWIVEL

Fedorischev V.S.

Scientific supervisor: candidate of technical science Konov V. N.

Language supervisor: Tsigankova E.V.

Siberian Federal University

The purpose of my research work is to diagnose, check the availability product index and retrofit drilling swivels.

Operation problems are:

- Diagnosing shared problems;
- Revealing defects of the most vulnerable knots and details;
- The technical offer promoting increase of swivel reliability.

Technical diagnostics is a component of operation, maintenance and repair. The primary goal of technical diagnosing is founding troubles, the prevention of failures. It promotes reduction of expenditures by maintenance and repair of objects. Hence, we receive reduction of monetary losses from idle time as a result of failures.

Diagnosing technical objects includes following functions:

- Estimation of object technical condition;
- Detection and definition of defects and malfunctions localization places;
- Forecasting residual resource of object;
- Monitoring of object technical condition.

Drilling swivel is a highly loaded construction retaining on weight gyrated drilling tool, with simultaneous heat input of flush fluid in a pipe string at well boring. Object of research is the technical condition of the swivel and its elements.

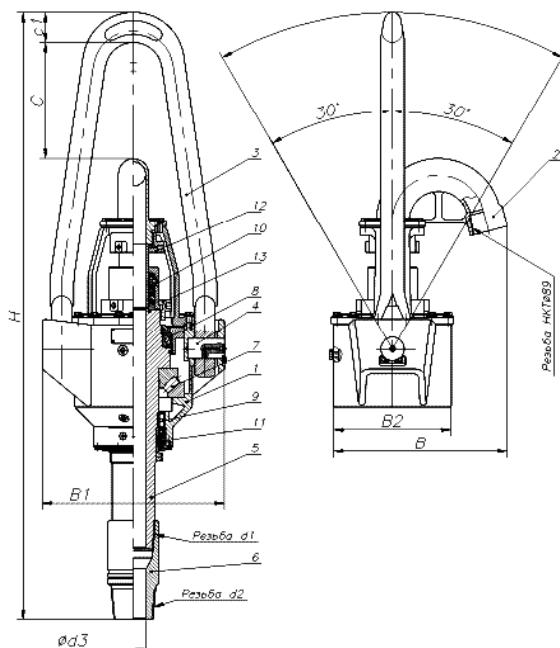

The swivel is a coupling link between tackle system and ancillary. The swivel should retain the drilling string hanged to it and to amortize at its sharp moves and to smooth out its hitches at trippings. And consequently it is responsible drilling equipment in respect of reliability. The swivel must to provide drilling tool trouble-free work, and also safety of servicers.

In a drilling swivel construction necessity of stope back washover by drill fluids in drilling-time is envisioned. Also, the swivel should have the enhanced factor of assurance because it is under the influence of high-pressure a washover mud and a multiton hangdown, and also efforts appended to it. The

swivel is validated on troubles at factory by an inspection department. The swivel also validates microscopy on the maintenance of incipient cracks and troubles at mould piece. Such careful check is carried out for the reason that at swivel breaking there is a severe emergency on a drill site owing to which one, the oil company incurs enormous losses, and, hence, there are also claims to the producer.

Now there are following methods of diagnosing:

- Sensual methods
- Vibrating methods
- Acoustic methods
- Thermal methods
- Specific methods for each of techniques areas

As to drilling swivels, methods of non-destructive check more often will be applied to them. Non-destructive check of swivels should be executed on central bases of industrial service and at mechanical-repair factories at overhauling of swivels. At non-destructive check of swivels on the present technology come to light surface and under surface troubles of type of fractures, initial tears, cavities and other disturbances of continuity of metal.

Parts of swivels and the zones subjected to non-destructive check

Part	Check zone	Methods	Identification of a zone of check on image
Bushing	Thread in accordance with GOST 5286-75	Ultrasonic check (UC), ferromagnetic	1a
Shaft	Thread, chamfers	UC, ferromagnetic	2a, 26
The body	Pockets, attachment zones	Visual, UC	3a, 36
Fingers (fulcrums)	-	Visual, magnetic	4a
Tube pressure (diversion)	Overbending zone (thickness)	UC	5a
Connecting link	Zone of fit to a wall hook, openings under fingers	magnetic, UC	6a, 66

In this table and picture all zones subjected to check are in detail described.

When the swivel is already down from the drilling unit on a repair station, it is necessary to knock down and carry out technical diagnostics of its parts and knots. One of the problem points thus is withdrawal of a finger from a connecting link collar to detach a connecting link from the body. For some reasons (small mobility of a finger, insufficient quantity of lubrication, a high offloading on this node), finger seizes in a

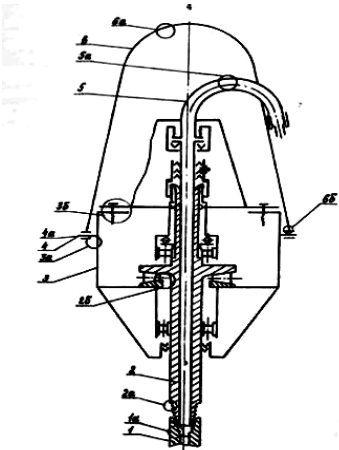

collar at on-stream, and now actual technical solution of this problem does not exist. And I tender three technical solutions. In my opinion, they are economic enough and quite realized on production.

1) Grooving of shaped tracks in a collar of a connecting link and on fingers.

I tender to cut through a shaped chisel (or something similar) tracks (*depth 1-2mm and diameter 3-5mm*) in a collar and on a surface of a finger with pipeline pitch in 1 revolution lengthwise a finger. When these tracks coincide, we can space fill their additional lubrication (cup grease). This is directly should preclude with grasping at operation of swivels.

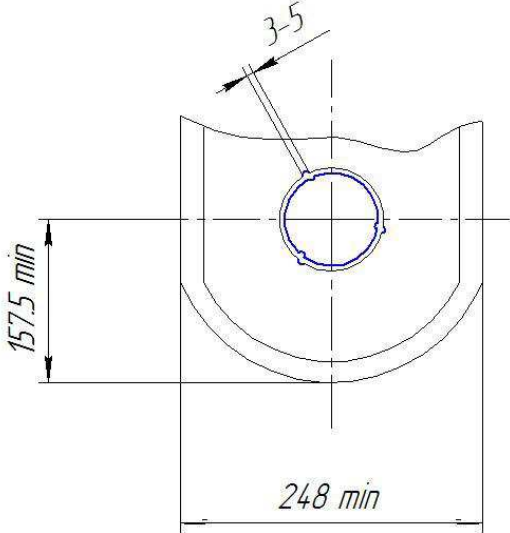

2) Magnification of diameter and a lead in a finger.

Finger withdrawal is held by means of a lifter, but the standard thread (*which one expressly for this purpose is in a finger*) does not bear a load and breaks frequently in the course of removal. I tender to augment diameter of this thread and to diminish its pitch. This operation can be effected on mechanical-repair bases where there is an analysis and swivel diagnostics. For an example we take drilling swivel US-250-MA. Gauge diameter of a thread in a finger of such swivel compounds 18mm, and a lead 2.5mm. We augment diameter of a thread to 22-24mm and we diminish its pitch to 1mm. In most cases there will be a successful withdrawal of a finger.

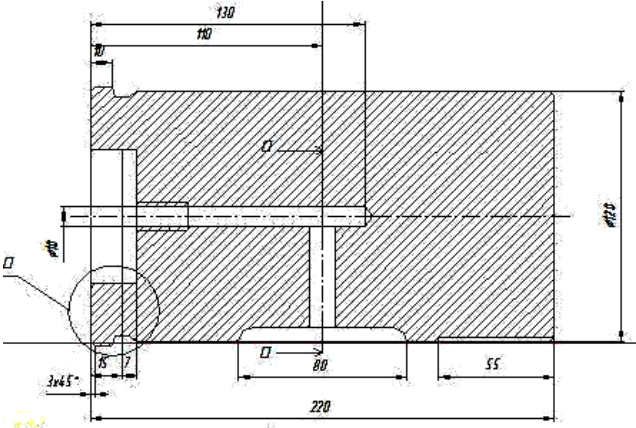

3) Quenching of a finger surface to higher hardness HRC=52-56 by means of high frequency currents.

The following method guesses magnification of durability of time which has already worked some period (1 year) a finger. Under standard documents, for a year, there is a finger abrading in diameter to 2mm. I tender to grind still 2mm and after to solder on it to a primary state special chrome-nickel a welding rod an additional stratum of metal. After that, it is necessary to handle a finger surface (to make its smooth) and to temper instant quenching by means of currents of high frequency. After done operations we will receive a finger, which one hardness of a surface will compound to 56 HRC, in comparison with the previous hardness number 32-36HRC. Also, I consider that it is necessary to take attention, as the collar of a connecting link and a finger are executed from an identical steel 38CrMgNi (or

look-alike). The produced retrofit will allow a finger to serve even longer, and also the odds of the next grasping should be diminished.

The produced methods are in process of adaptation and only partially have been realized. In my opinion, they should simplify really process of tear-down of drilling swivels, and also will enhance reliability and durability of investigated parts, and consequently also the drilling swivel as a whole.

References:

- 1) Pronikov A.S. “Parametric reliability of ambulances”: *the scientific edition, 2003. - 592 pages.*
- 2) Makushkin D.O. “Diagnostics and restoration of the oil and gas equipment”: *the manual/ Krasnoyarsk.: IPS KGTU, 2002. 142 pages.*
- 3) Protasov V. N, Sultanov B. Z, Krivenkov S.V. “Operation of the equipment for well boring and for oil and gas recovery”: *the manual for high schools: Open Company "Mineral resources-business centre", 2004. - 691 pages.*
- 4) Dobrynin S.L, Pavlova S.N, Meleizhn V.F. “Technology of non-destructive check of swivels RD 39-12-1150-84”: *the supervising document.*
- 5) Ilskij A.L, Mironov J.V, Chernobyl A.G. “Calculation and drilling equipment designing”: *the manual for high schools. Moscow, 1985. 452 pages.*